

E

# Low Profile Economy Retail Refrigeration Pump (EERP)

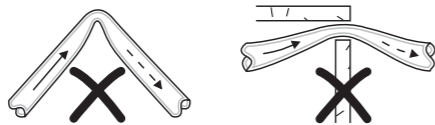

El flotador debe estar siempre colocado alrededor de su eje, con el iman en la parte superior.

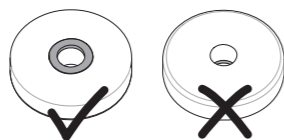

**IMPORTANTE:** Por higiene y por rendimiento recomendamos colocar un antibacterias "Stayclean" entre los dos filtros del depósito. El " Stayclean " debe estar SIEMPRE colocado entre los dos filtros del depósito, y NO en la cámara del flotador.

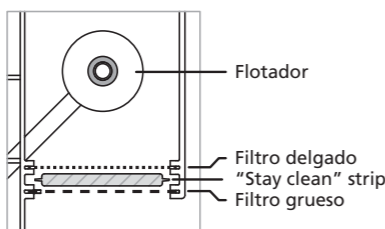

**IMPORTANTE:** A esta bomba solo debe conectarse una unidad de refrigeración.

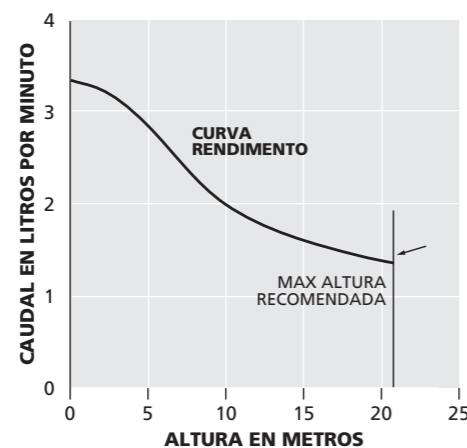

## Especificaciones Técnicas:

- Depósito y tapa de molde inyectado
- Capacidad del depósito: 3.5 litros
- Caudal máximo de agua: 190 litros por hora
- Máxima altura recomendada: 21 metros
- Motor protegido termicamente
- 1.6 A máx. 30 W máx.
- Microrruptor de seguridad de nivel alto
- Orificio de entrada en la tapa del depósito: 50mm
- Conexión al tubo de salida: 10mm
- Filtro impurezas
- Temperatura del agua: 0°C a 40°C

## Dimensiones:

Alto: 75mm Ancho: 530mm  
Fondo: 240mm Peso: 2.4kg

## Conexiones eléctricas:

Marrón: Fase  
Azul: Neutro  
Verde/amarillo: Tierra  
Negro: N/C  
Negro: Común

## Descripción:

Esta bomba ha sido diseñada para ser instalada debajo de las vitrinas frigoríficas para recoger el agua que se produce durante el ciclo de desescarche, cuando el drenaje directo no es posible. La bomba es accionada por un flotador/sensor a efecto hall y puede evacuar el agua hasta una altura máxima de 21 metros.

Están provistas de un microrruptor de nivel de seguridad capaz de desconectar la unidad, o de conectar una alarma sonora en el caso de un fallo de la bomba.

## Notas sobre la instalación:

La bomba ha sido diseñada para ser colocada a nivel, sobre su base. Asegurarse de que no hayan dobleces u obstrucciones en el tubo de descarga, el cual debe tener un diámetro interno de 9mm y debe de estar asegurado mediante una brida a la salida de la bomba.

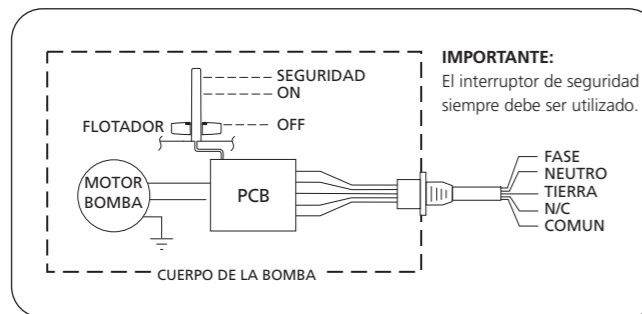

# Compact Economy Retail Refrigeration Pump (C.E.R.R.P.)

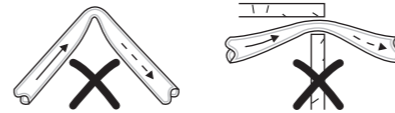

Il galleggiante deve essere sempre posizionato intorno alla colonna di alloggio del galleggiante, con il magnete rivolto verso l'alto.

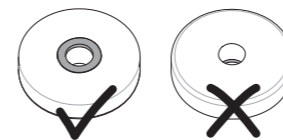

**IMPORTANTE:** Per un' accurata igiene e per mantenere le prestazioni, si raccomanda vivamente l'utilizzo di strisce anti-batteriche ("Stay Clean Strip") da posizionarsi SEMPRE fra i due filtri all'interno del serbatoio e MAI nel vano contenete il galleggiante.

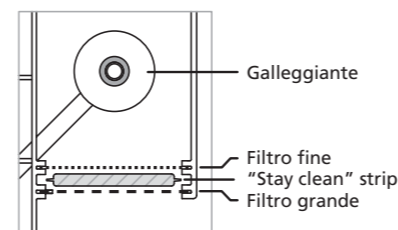

**IMPORTANTE:** Utilizzare questa pompa per lo scarico di un'unica unità refrigerante.

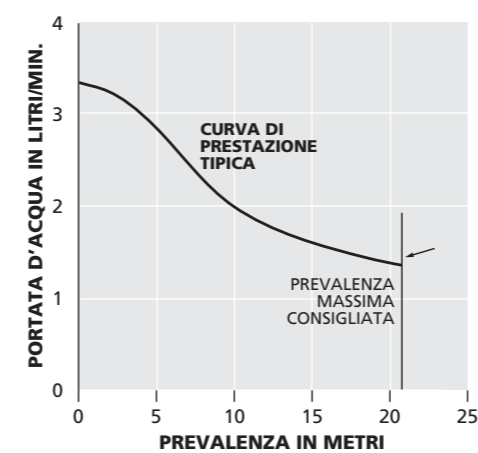

## Specifiche Tecniche:

- Vasca di raccolta e coperchio in materiale plastico stampato con processo ad iniezione
- Capacità del serbatoio : 3.5 litri
- Portata massima : 3,3 litri/min (= 190 litri/hr) con prevalenza zero
- Prevalenza massima consigliata : 21 metri
- Motore con funzionamento ad intermittenza dotato di protezione termica
- Alimentazione: 230v 50Hz
- Assorbimento massimo: 1.6 A – 30 W
- Interruttore di sicurezza per alto livello
- Diametro del foro di entrata sul pannello di copertura: 50mm
- Diametro del manicotto di connessione alla tubazione di scarico: 10mm
- Presenza ad innesto rapido (alimentazione/cavi allarme)
- Filtro anti-detrimenti
- Temperatura minima/massima dell'acqua di scarico : 0°C / 40°C

## Dimensioni:

Altezza: 75mm Larghezza: 530mm  
Profondità: 240mm Peso: 2.4kg

## Collegamenti elettrici:

Marrone: Fase  
Blu: Neutro  
Verde/Giallo: Terra  
Nero: N/C  
Nero: COMUNE

## Descrizione:

La pompa è progettata per essere installata sotto i banchi frigo per raccogliere l'acqua di condensazione durante il ciclo di sbrinamento ed evacuarla a distanza, quando non è possibile lo scarico diretto. La pompa è innescata da un sistema a galleggiante (sensore di livello) con effetto Hall ed è in grado di scaricare l'acqua ad un'altezza massima (prevalenza verticale) di 21 metri.

E' inoltre dotata di un interruttore di sicurezza per l'alto livello dell'acqua di scarico, che permette sia l'arresto dell'impianto frigo che l'attivazione di un allarme (non incluso) visivo o sonoro in caso di guasto della pompa.

## Note d'installazione:

Questa pompa è progettata per essere installata in piano, sulla propria base. Assicurarsi che non ci siano strozzature della tubazione o residui al suo interno. Il tubo di scarico deve avere un diametro interno di 10 mm ed essere fissata con una fascetta al manicotto di uscita della pompa.

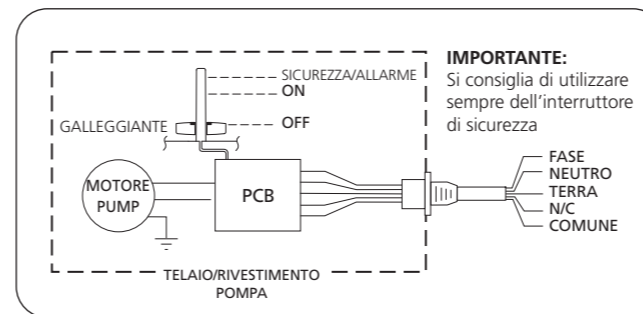

# ASPEN PUMPS

Aspen Pumps Apex Way Hailsham East Sussex BN27 3WA  
t +44 (0)1323 848842  
f +44 (0)1323 848846  
www.aspenpumps.com  
sales@aspenpumps.com



## DATA SHEET: Low Profile Economy Retail Refrigeration Pump

## FICHE TECHNIQUE: ERVR Economique petit bac

## DATENBLATT: Cold Cabinet Eco Slimline

## DATOS TÉCNICOS: Low Profile Economy Retail Refrigeration Pump

## DATI TECNICI: Compact Economy Retail Refrigeration Pump (C.E.R.R.P.)

## DECLARATION OF CONFORMITY

G.B. It is hereby certified that the Aspen electric motor driven pumps as above comply with the essential Health & Safety requirements of the "Machinery Directive" having the reference as given overleaf.

MACHINERY DIRECTIVE  
(89/392/EEC amended by 91/368/EEC, 93/44/EEC and 93/68/EEC)  
(Electromagnetic Compatibility Directive - 89/336/EEC amended by 92/31/EEC)  
(Low Voltage Directive - 73/23/EEC amended by 93/68/EEC)



Signed: *B. Reed* Quality Assurance Manager



Manufactured in the UK by ASPEN PUMPS® • Pat. Pending

**GB**

# Low Profile Economy Retail Refrigeration Pump (EERP)

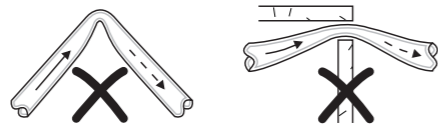

The float must always be located around the float column, with the magnet uppermost:

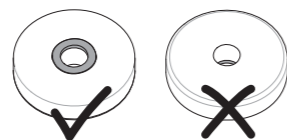

**IMPORTANT:** For hygiene and performance, we strongly recommend an anti-bacterial "Stayclean" strip is ALWAYS positioned between the two filters in the tank. The anti-bacterial strip must be BETWEEN the two filters and NOT in the float chamber:

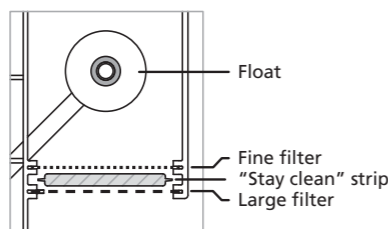

**IMPORTANT:** Only one refrigeration unit must drain into this pump.

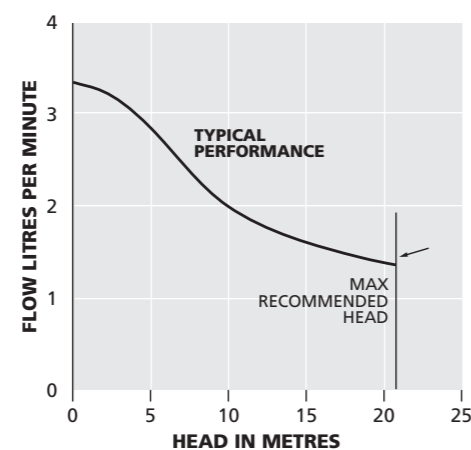

## Technical Specification:

- Injection moulded tank/covers
- Tank capacity: 3.5 litres
- Maximum water flow rate: 190 litres per hour
- Maximum recommended head: 21 metres
- Thermally protected Intermittent Duty rated motor
- 230v 50Hz
- 1.6 A max. 30 W max.
- High level safety switch
- Inlet hole in tank cover: 50mmØ
- Outlet hose connection: 10mmØ
- Push-in plug
- Filter to catch debris
- Water temperature: 0°C to 40°C

## Dimensions:

Height: 75mm Width: 530mm  
Depth: 240mm Weight: 2.4kg

## Electrical Connections:

**Brown:** Live  
**Blue:** Neutral  
**Green/yellow:** Earth  
**Black:** N/C  
**Black:** Common

## Description:

The pump is designed to be installed underneath 'island' refrigeration units to collect water during the defrost cycle, where direct drainage is not available. The pump is triggered by a hall-effect float/sensor arrangement and will discharge the water to a maximum height of 21 metres to a suitable drain.

There is a high level safety switch which will either enable the plant to be switched off or sound an alarm in the event of a pump failure.

## Installation Notes:

This pump is designed to sit level on its base.

Ensure that there are no kinks or trapped parts in the discharge piping, which must have an internal diameter of 9mm and be secured to the pump outlet with a clamp.

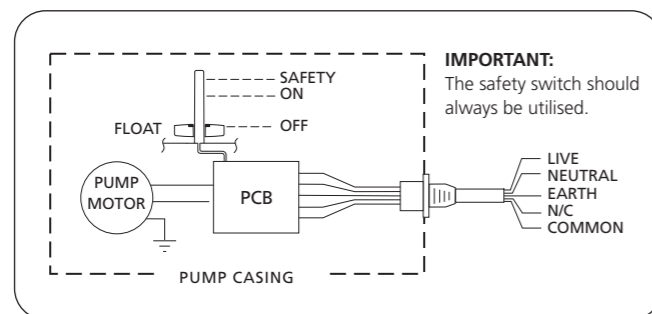
**F**

# ERVR Economique petit bac

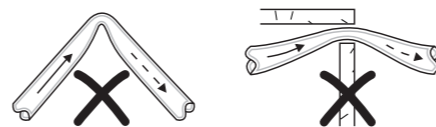

Le flotteur doit toujours être placé sur l'axe de l'électro-aimant, avec l'aimant toujours placé vers le haut.

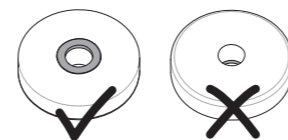

**IMPORTANT:** Pour nous recommandons fortement d'utiliser le bandeau antibactérien "STAYCLEAN". Il doit être placé dans le bac entre les deux filtres. Le bandeau anti-bactérien doit être placé entre les deux filtres et surtout pas dans la zone du flotteur.

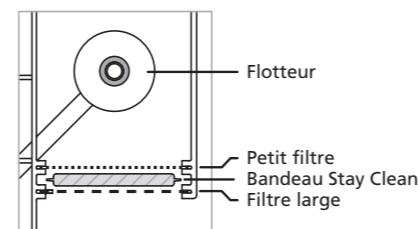

**IMPORTANT:** La pompe doit récupérer les condensats d'une seule vitrine réfrigérée.

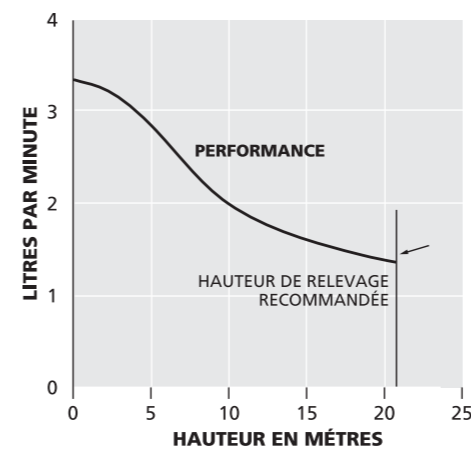

## Caractéristiques techniques:

- Bac et couvercle en PCV
- Capacité du réservoir: 3.5 litres
- Débit maximum de la pompe: 190 litres par heure
- Hauteur de refoulement maximum: 21 mètres
- Moteur protégé par une protection thermique
- 1.6 A max. 30 W max.
- Protection thermique du moteur
- Contact d'alarme
- Orifice sur le dessus du bac: 50 mm Ø
- Refoulement des condensats: 10 mm Ø
- Prise électrique : type informatique
- Température de l'eau : 0° à 40°C

## Dimensions:

Hauteur: 75mm Largeur: 530mm  
Profondeur: 240mm Poids: 2.4kg

## Connexions électriques:

**Marron:** Phase  
**Bleu:** Neutre  
**Vert/jaune:** Terre  
**Noir:** N/C  
**Noir:** Commun

## Description:

L'ERVR économique est destiné à être installé sous des vitrines réfrigérées et à évacuer les condensats de ces vitrines. Les condensats de cycle de dégivrage peuvent être récupérés grâce au grand volume du bac. La mise en marche et l'arrêt de la pompe se fait grâce au flotteur situé dans le bac de ERVR. La hauteur maximum de relevage est de 21 mètres.

Le niveau haut du flotteur correspond au niveau d'alarme, si le niveau haut est atteint, il est possible de couper l'alimentation électrique de la vitrine ou le déclencher une alarme sonore.

## Installations:

Cette pompe est faite pour être posée à plat sur le sol. Assurez-vous que la tuyauterie de refoulement ne soit pas pincée ou pliée. La tuyauterie de refoulement doit avoir un diamètre interne de 9mm et être fixée à la sortie de pompe avec une bride.

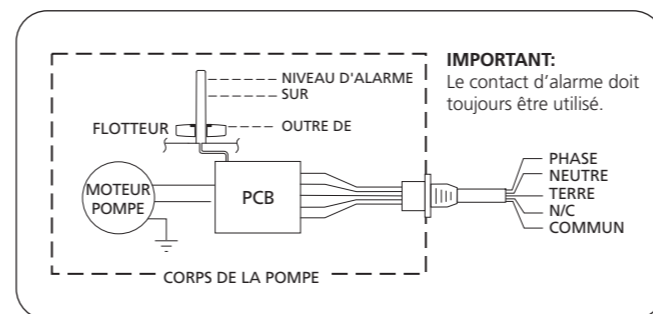
**D**

# Cold Cabinet Eco Slimline

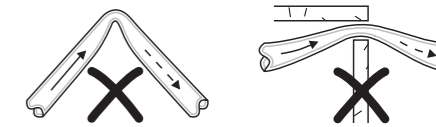

Der Schwimmer muss immer mit dem Magneten nach oben auf der Führungsstange positioniert werden.

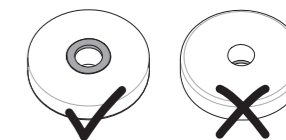

**Wichtig:** Aus Hygiene- und Leistungsgründen empfehlen wir dringend, einen antibakteriellen "Stay clean"-Streifen zu verwenden. Dieser Streifen muss zwischen die beiden Filter und nicht innerhalb der Schwimmerkammer gelegt werden.

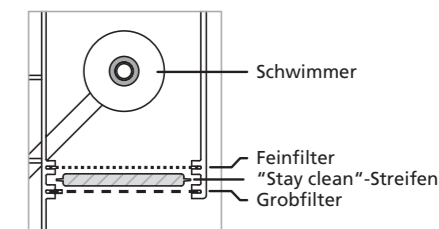

**Wichtig:** Sie können nur eine Kühleinheit an diese Pumpe anschließen.

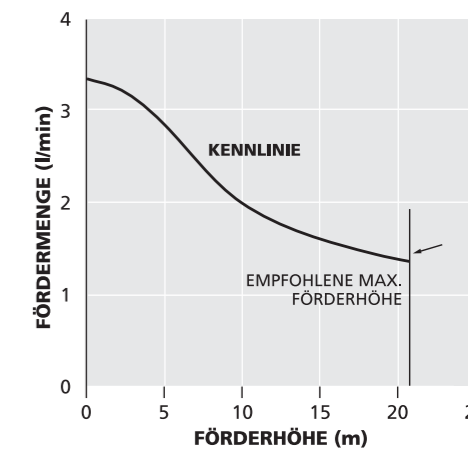

## Technische Spezifikation:

- Tank und Abdeckung aus Kunststoff
- Behälterfassungsvermögen: 3.5 Liter
- Maximale Fördermenge: 190 Liter/h
- Maximale Förderhöhe: 21 Meter
- Thermisch geschützter, periodisch arbeitender Motor
- Max. 1,6 A, Max. 30 W
- Sicherheitsschalter
- Einfüllstutzen: 50 mm Ø
- Druckanschluss: 10 mm Ø
- Netzanschluss per Stecker
- Schmutzfilter
- Zulässige Wassertemperaturen: 0 – 40°C

## Abmessungen:

Höhe: 75mm Breite: 530mm  
Tiefe: 240mm Gewicht: 2.4 kg

## Elektroanschlüsse:

**Braun:** Phase  
**Blau:** Null-Leiter  
**Grün/Gelb:** Schutz-Leiter

## Sicherheitsschaltung:

**Schwarz:** Phase  
**Schwarz:** Öffnerkontakt

## Beschreibung:

Diese Pumpe ist konstruiert worden, um unterhalb von Kühltheken eingebaut zu werden. Während des Abtau-Prozesses kann sie das Tauwasser aufnehmen, wenn es keinen natürlichen Ablauf gibt. Die Pumpe wird durch eine Hall-Steuerung geschaltet und hat eine maximale Förderhöhe von 21 m.

Sie besitzt einen Sicherheitsschalter der als Öffnerkontakt ausgelegt ist.

## Einbauanweisung:

Installieren Sie die Pumpe waagrecht.

Achten Sie darauf, dass der Druckschlauch keine Knicke aufweist oder eingeklemmt ist.

Der Druckschlauch muss einen Innendurchmesser von 9 mm haben und muss fest mit dem Druckanschluss der Pumpe verbunden werden.

