



Solar Systems

the complete mounting system
for photovoltaic panels on a flat roof

www.bigfootsystems.co.uk



An introduction to us

Big Foot Systems have been designing and manufacturing support systems for air conditioning ventilation and refrigeration on flat roofs for 10 years and exporting to many parts of the world.

We have continued to add new products to our range and recently our customers asked us to produce a low cost, robust, quick to install support system for a growing market of consumers who want to install PV panels on their buildings.

The new feed in tariffs for PV have created a market place for small to medium size installations and customers want to be green, but at the same time want a return on their investment.

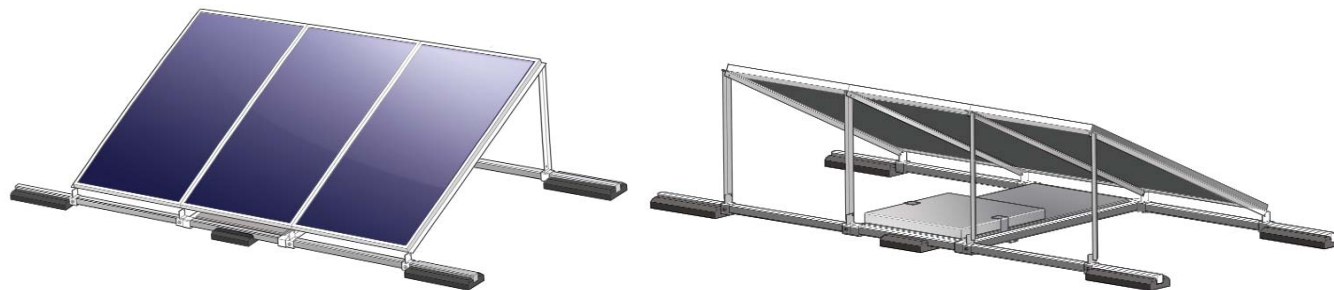

We have attempted to address all these issues by producing a simple flexible system that's quick to install, and consequently makes the whole process flow from the moment you take the first step to the moment your making your own electricity.

We provide you with recommended ballast weights and fixings to ensure that your installation is well secured in high winds, plus a 15 year product warranty!

Index

- 1 An introduction to us
- 2 Galvanised platform
- 3 Concrete slab installation
Wind loading
- 4 Fix-it Foot
- 5 Medium & large systems
- 6 Fixing the panels
- 7 Enquiry form

Galvanised platform

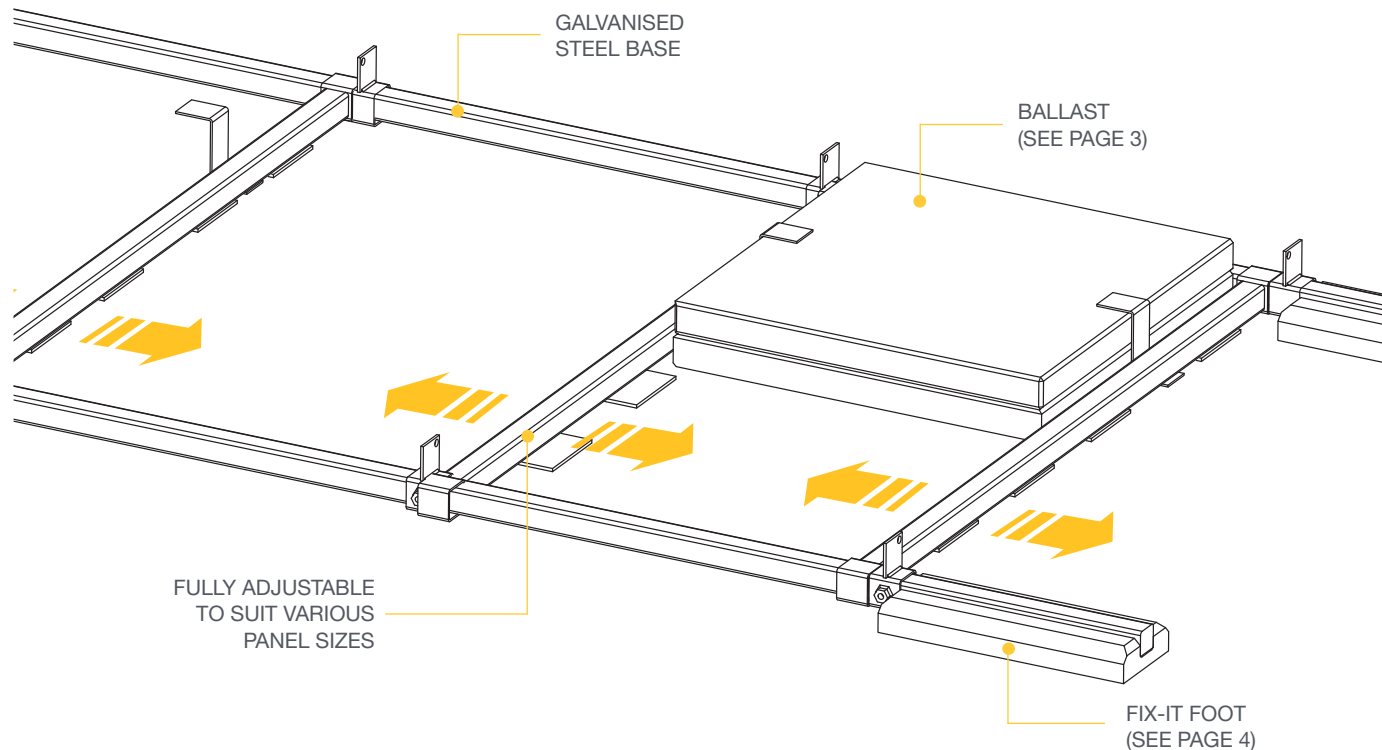

- For supporting photovoltaic panels on a flat roof
- Framework: 40mm x 40mm x 2.5mm thick steel tube
- Priced by the metre
- Quick installation setup time: 10 metres in 5 minutes

Platform

Hot Dipped Galvanised steel to Safety Standard BS EN ISO 1461:1999 for maximum corrosion resistance for all year round intense weathering and extreme storm conditions.

Bonding the platform to the Fix-it Foot
For extra lasting hold use exterior contact adhesive or Antel aerosol contact adhesive.

Concrete slab installation

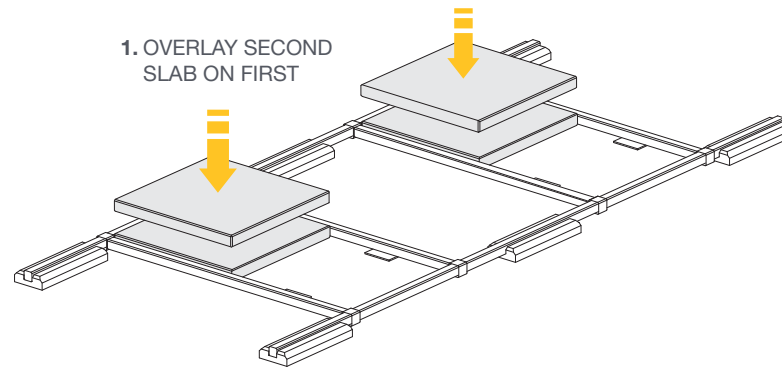
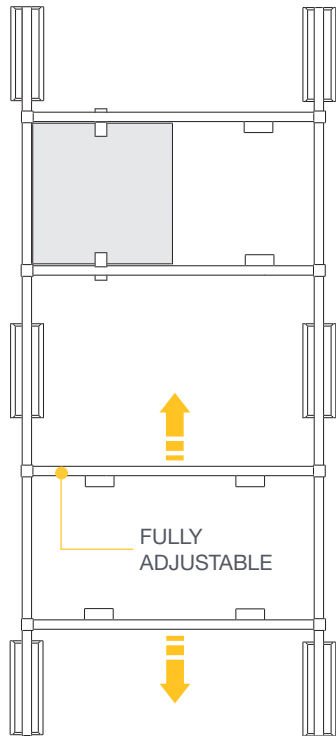

1. OVERLAY SECOND SLAB ON FIRST

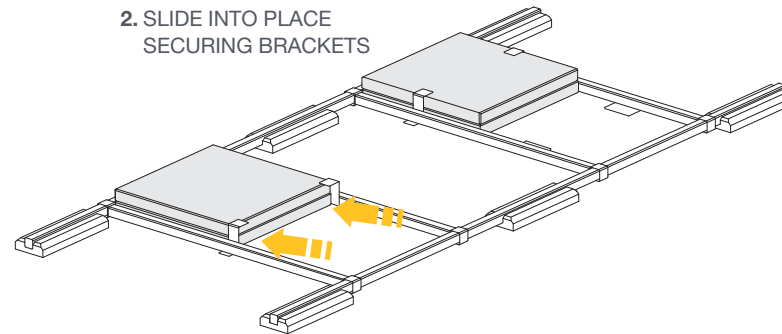

2. SLIDE INTO PLACE SECURING BRACKETS

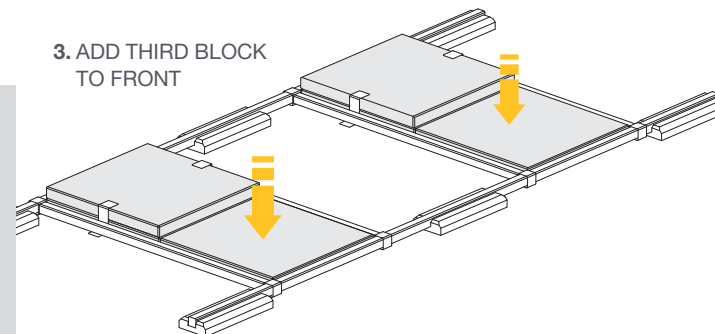

3. ADD THIRD BLOCK TO FRONT

- Quick and cost effective ballast
- Commercial paving slabs readily available from builders merchants ensure recommended ballast loading
- Secured with easy fix brackets supplied

Wind loading

- Big Foot Solar Systems are ballasted in accordance to BS6399 Part 2 'Loading for buildings. Code of practice for wind loads' and BRE Digest 489 document 'Wind loads on roof based photovoltaic systems'.
- An assessment is made based on the solar panel size, quantity, pitch and mass of the panel(s) then calculated to obtain the required ballast. Terrain, topography, building height etc. all plays a part in this calculation.
- The table below provides the ballast requirements for solar panels up to this size and mass. However should your panel(s) be larger, then contact us first.
- If frames can be fixed or wired to parts of the building structure, ballast may be reduced.

Panel dimensions	Panel weight	Angle	Recommended ballast per lnr. mtr.
1500 x 1000mm (1.5m ²)	15kg min.	25°-45°	126kg (3 slabs*)
*slab size 600 x 600mm, weighing 42kg each			

Fix-it Foot

FIX-IT FOOT 400



FIX-IT FOOT LOW 400



- Four sizes of Fix-it Foot available
- Spreads the weight without penetrating the roof membrane
- Made from durable recycled rubber which offers built-in anti-vibration
- U.V. stabilised

IN CASE YOU ARE CONSTRUCTING YOUR OWN FRAMEWORK... USE FIX-IT FOOT!					
Fix-it Foot	Length (mm)	Width (mm)	Height (mm)	Weight (kg)	Max. load per foot (kg)
250 Low	250	130	50	1.1	50
400 Low	400	130	50	1.7	100
250	250	180	95	2.3	100
400	400	180	95	3.7	200

The Fix-it Foot is a neat and tidy support solution from Big Foot. Made from durable recycled rubber with a channel moulded into the top face, allowing fixing of 40 x 40mm box section or strut.

Recesses in the underside allow for small debris on the roof surface. The recycled rubber also offers built-in anti-vibration and is economical as well as being environmentally responsible.

Quality Assurance

Raw materials are selected from ISO9002 registered suppliers.

Construction

Pressure moulded using a 1 or 2 part mix, utilising milled, sieved & graded Styrene Butadiene Rubber (SBR-Recycled Rubber). Bound using a ratio of high quality moisture curing Polyurethane Pre-Polymer. Manufactured with a built in shrinkage allowance.

Safety Standards

British Standard BS7188:1989
& BS5696 Part 3:1979
European Standard PR EN 1177
U.S.A. Standard ASTM F 1292-99

Medium & large systems

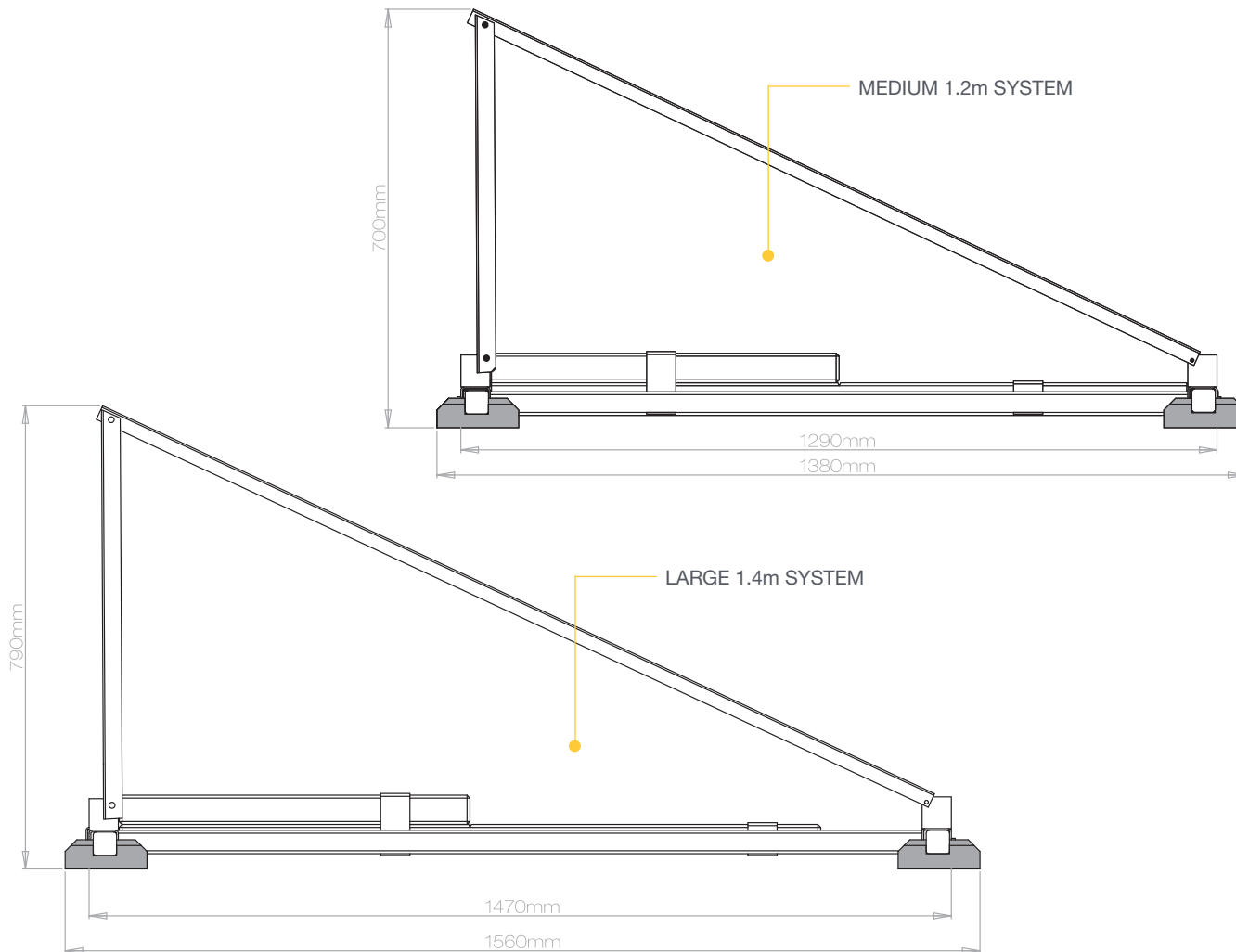

We have engineered our Big Foot Solar Systems to meet the need for a support that will be highly secure and compatible for differing sizes of solar panels on flat roofs.

Two fundamental solar system sizes accommodate most manufacturers panels:

- **Medium 1.2m System**
- **Large 1.4m System**

General solar panel size variants (mm)	System size
1310 x 990	Medium
1318 x 994	Medium
1370 x 740	Medium
1482 x 992	Large
1559 x 798	Large
1576 x 798	Large
1580 x 798	Large
1650 x 990	Large
1652 x 994	Large

Fixing the panels

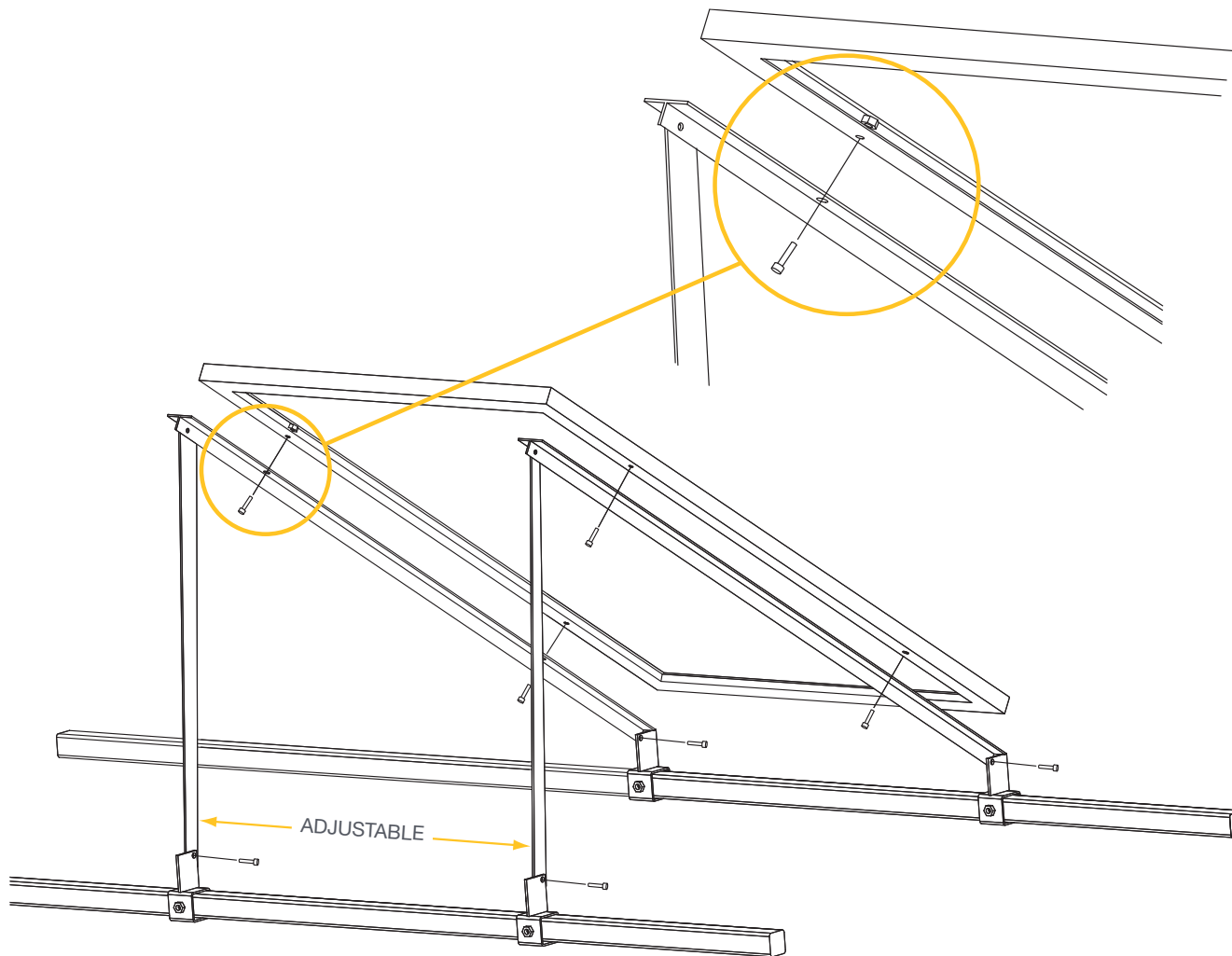

Drill on site

1. Drill through solar panel and aluminium support (hole size: 7mm diameter)
2. Recommended PV solar panel fixing bolt:
 - M6 x 20mm zinc plated bolt x 4
 - M6 stainless steel Nyloc nut x 4

Ensure stainless steel self locking Nyloc nut spring washers are used throughout installation fixings.



Enquiry form

Contact details

Contact name:
.....
.....

Company name:
.....
.....

Address:
.....
.....
.....
.....

Postcode:

Telephone no:
.....

Email address:
.....

Panel details

Panel quantity:
Panel size (L) x (W) x (D):
Panel weight (kg):
Panel array preference (e.g. straight line / bank of two rows etc.):

Building details

Building roof height:
Site location (town / county):
Roof build-up / waterproofing membrane (if known):

Roof drawing? (if available) yes no New access through roof proposed? yes no
Structural limitations? yes no New pedestrian access platform to roof required? yes no
Roof space restrictions? yes no Specific height off roof required? yes no

Additional notes:

- The panel(s) location, aspect, weather, shade and tilt should all be considered as they may affect the panel(s) performance.
- Big Foot Solar Systems can be assembled very rapidly at approximately 8 metres per hour based on two people installing.
- Big Foot Solar Systems takes no responsibility for the condition of the roof on which our equipment is to be used. You must ensure that the substrate on which the Big Foot is intended for use is structurally sound enough to take the weight and point loadings we have indicated. All Big Foot products must be installed in line with the guarantees and recommendations of the manufacturer of the roofing system. The manufacturer of PVC membranes should advise on the susceptibility to migration of plasticizers and specific recommendations should be adhered to so that the roof guarantee is not affected.